

Installation and Start-up Guide

efesotomasyon.com

RS485 and RS232 Adapter
for product type ACS 140



ACS 140
RS485 and RS232 Adapter

**Installation and Start-up
Guide**

3AFY 61492828 R0125 REV A
EN
Effective: 1.10.1998

efesotomasyon.com

Safety Instructions

Overview

This chapter states the safety instructions that must be followed when installing and operating the RS485/RS232 adapter. If neglected, physical injury and death may follow, or damage may occur to the frequency converter, the motor and driven equipment. The material in this chapter must be studied before attempting any work on, or with, the unit.

Warnings

Warnings are used to inform of conditions which can, if proper steps are not taken, lead to a serious fault condition, physical injury and death.

Readers are informed of situations that can result in serious physical injury and/or serious damage to equipment with the following symbols:



Dangerous Voltage Warning: warns of situations in which a high voltage can cause physical injury and/or damage equipment. The text next to this symbol describes ways to avoid the danger.



General Warning: warns of situations which can cause physical injury and/or damage equipment by means other than electrical. The text next to this symbol describes ways to avoid the danger.

General Safety Instructions



WARNING! All electrical installation and maintenance work on the ACS 140 should be carried out by qualified electricians.

The ACS 140 and adjoining equipment must be properly earthed.

Do not attempt any work on a powered ACS 140. After switching off the mains, always allow the intermediate circuit capacitors 5 minutes to discharge before working on the frequency converter, the motor or the motor cable. It is good practice to check (with a voltage indicating instrument) that the frequency converter is in fact discharged before beginning work.

The ACS 140 motor cable terminals are at a dangerously high voltage when mains power is applied, regardless of motor operation.

There can be dangerous voltages inside the ACS 140 from external control circuits when the ACS 140 mains power is shut off. Exercise appropriate care when working with the unit. Neglecting these instructions can cause physical injury and death.



WARNING! There are several automatic reset functions in the ACS 140. If selected, they reset the unit and resume operation after a fault. These functions should not be selected if other equipment is not compatible with this kind of operation, or dangerous situations can be caused by such action.

Because of the variety of uses for this equipment and because of the differences between this solid-state equipment and electromechanical equipment, the user of and those responsible for applying this equipment must satisfy themselves as to the acceptability of each application and use of the equipment. In no event will ABB be responsible or liable for indirect or consequential damages resulting from the use or application of this equipment.

Table of Contents

Safety Instructions	iii
Overview	iii
Warnings	iii
General Safety Instructions	iv
Chapter 1 – Introduction	1
Overview	1
Delivery Check	1
How to Use This Guide	1
Conventions Used in This Guide	2
Using the Adapter with ACS 400	2
Chapter 2 – Installation	3
Overview	3
Mounting	4
Selecting the Communication Speed	4
Selecting RS485 or RS232 Mode	5
RS485 Bus Termination	5
Installation to RS485 Bus	6
Installation to RS232 Bus	8
Earthing and Termination	10
Chapter 3 – Programming	11
General	11
Communication Settings	12
Control Locations	14
Diagnostic Counters	19
Chapter 4 – Communication	21
Introduction to Modbus	21
Register Read and Write	21
Register Mapping	22
Exception Codes	23
Function Codes	23
The Command Word	24
References	25
The Status Word	26
Actual Values	27
Fault and Alarm Status	29
Chapter 5 – Fault Tracing	31
Appendix – Parameter Scaling	33
Effect of Resolution	33
Signed Values	33

Chapter 1 – Introduction

Overview

The RS485 and RS232 adapter is used for connecting the ACS 140 frequency converter to a serial Modbus (RS232 or RS485) network. The adapter can also be used with the ACS 400 frequency converter.

Delivery Check

The option package includes:

- RS485/RS232 Adapter
- Installation and Start-up Guide for RS485 and RS232 Adapter

How to Use This Guide

The purpose of this Guide is to provide the information necessary to install, commission, use, and to fault diagnose the adapter.

Safety Instructions describe the formats for warnings and notations used within this guide. This chapter also states the safety instructions which apply to the installation and operation of the RS485/RS232 Adapter.

Chapter 1 – Introduction, the chapter you are reading now, contains a short description of this manual and a list of related publications.

Chapter 2 – Installation contains instructions for mechanical and electrical installation of the adapter.

Chapter 3 – Programming explains how to program the ACS 140 drive for Modbus communication, and what additional parameters are available with the module.

Chapter 4 – Communication describes the Modbus communication on ACS 140 drives.

Chapter 5 – Fault Tracing describes how to diagnose the most common problems with the adapter.

Appendix – Parameter Scaling contains a complete list of all the parameters, their 4xxxx register addresses, and the scaling accessible through the Modbus network.

Conventions Used in This Guide

This manual uses some terms and conventions which might not be known to every user of this manual. Some of these terms are described below.

4XXXX Register Area

Modicon PLCs have a signed integer data table area, which is used for Analogue Output modules and for storing temporary or set-point values. These registers are in the address area starting from 40001. The last register address available on PLCs depends on the available memory, but is less than 49999.

The ACS 140 drive simulates this area by providing a read and write access to its parameters through this register address area.

Related Publications

ACS 140 Programming Guide.

Using the Adapter with ACS 400

The RS485 and RS 232 adapter can also be used with the ACS 400 frequency converter.

The ACS 400 frequency converter has two serial ports or channels as standard: RS485 connection (Channel 1) and serial port for the control panel (Channel 0). Normally when Modbus control is desired, Channel 1 is used. Channel 0 can be used to connect the *DriveWindow* Light PC tool. In this case, the control panel is replaced by the adapter.

When using the adapter with the ACS 400 and *DriveWindow* Light, note the following:

- There is no need to set any ACS 400 parameters: Channel 0 communication settings cannot be modified. Communication settings for Channel 0 are given in Table 2 on page 11.
- The contents of this guide need to be observed only to the extent that is needed to set up the DIP switches and jumpers of the adapter (Chapter 2 – Installation).

Chapter 2 – Installation

This chapter contains instructions for setting up the RS485/RS232 adapter.



WARNING! Verify that the ACS 140 is not powered before starting the installation.

Overview

The adapter operates either in RS232 mode or RS485 mode. The mode can be selected with a jumper. By default, the adapter operates in RS485 mode at a communication speed of 9600 bps (bits per second).

Remove the front cover to access the configuration switches and jumpers.

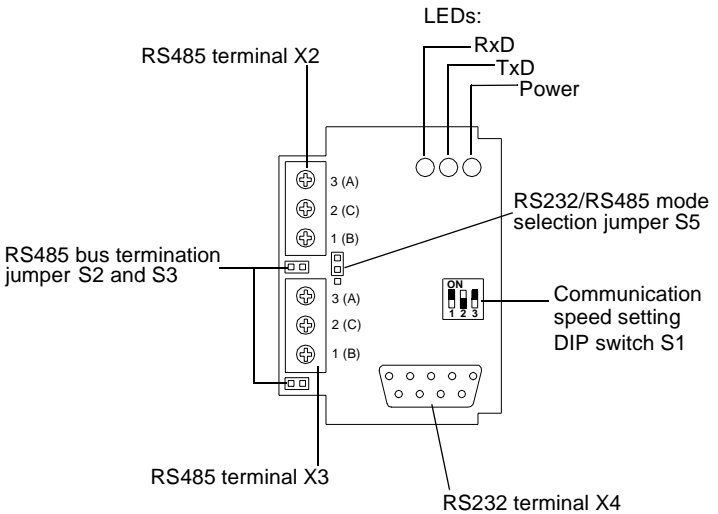


Figure 1 Connectors and switches.

Mounting

The adapter replaces the optional ACS100-PAN control panel. To eliminate the stress caused by the cables, use a strain relief.

Selecting the Communication Speed

Communication speed is selected by DIP switch S1 and by parameter 5201 COMM SPEED. The factory setting for the communication speed is 9600 bps (bits per second).

Communication speed setting using DIP switch S1 is needed only when the adapter operates in RS485 mode.


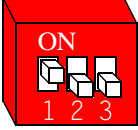

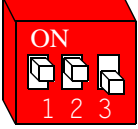
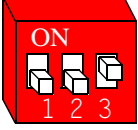
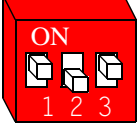
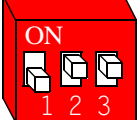
DIP switch S1	Communication speed
	300 bps
	600 bps
	1200 bps
	2400 bps
	4800 bps
	9600 bps
	19200 bps

Figure 2 Selecting the communication speed for the adapter.

Selecting RS485 or RS232 Mode

The adapter operates either in RS232 mode or in RS485 mode, selectable by a jumper. As a factory setting, the adapter operates in RS485 mode.

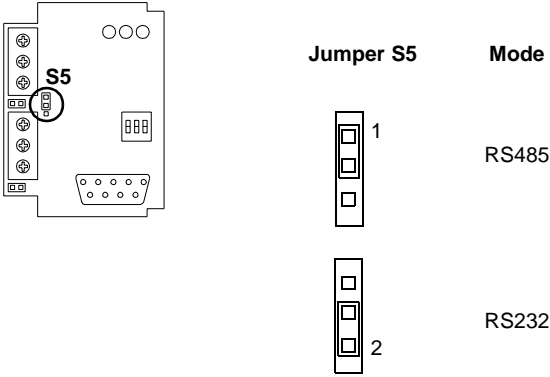
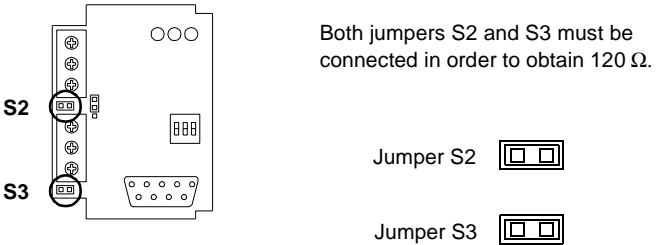


Figure 3 Selecting the operating mode.

RS485 Bus Termination

The RS485 bus must be terminated using $120\ \Omega$ resistors at both ends of the network. The adapter has built-in termination resistors that can be enabled by jumpers S2 and S3. Refer to “Earthing and Termination” on page 10. By default, bus termination is enabled.



If no termination is needed, both jumpers S2 and S3 must be opened.

Figure 4 Selecting RS485 termination impedance.

Installation to RS485 Bus

- 1 Make sure power is not connected to the ACS140.
- 2 Connect the ACS100-PAN control panel to the drive.
- 3 Connect power to ACS140.
- 4 Set up communication: station number, communication speed of the ACS 140 and parity. Refer to Chapter 3 – Programming.
- 5 Set up other drive parameters as needed. Refer to ACS140 Programming Guide and chapter 3 of this manual.
- 6 Disconnect power from the ACS140.
- 7 Set communication speed of the adapter with DIP switch S1.
- 8 Confirm that the operation mode is RS485 (jumper S5).
- 9 If the termination is not needed, remove jumpers S2 and S3 to disable it.
- 10 Connect the adapter to the ACS 140 and wire it to the RS485 network.

Skip steps 2-6 if the default parameter settings of the ACS 140 can be used.

Wiring

The RS485 link is a daisy-chained bus, without dropout lines. The RS485 link should also be terminated on both physical ends of the wire to reduce the noise on the network.

Modbus network should be wired using Belden 9841 or equivalent. Belden 9841 is a single twisted shielded pair cable with a wave impedance of 120 Ω .

The network should be connected according to Figure 5 below. The connection of both the incoming and outgoing cables to the same terminal enables the disconnection of the module without disturbing the communication between other stations.

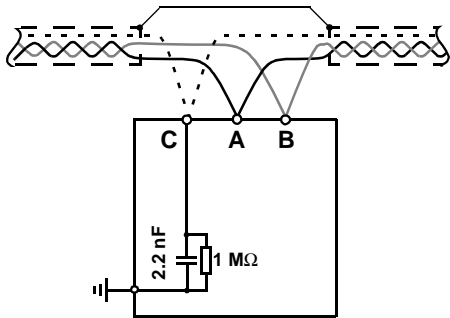


Figure 5 RS485 wiring. The cable shield can be left unearthed. Signal C (common) is connected to ACS 140 chassis through 1 MΩ impedance.

Table 1 RS485 connection terminals. Terminals X2 and X3 are connected in parallel.

X2, X3		Description
1	B	Data
2	C	Common
3	A	Data

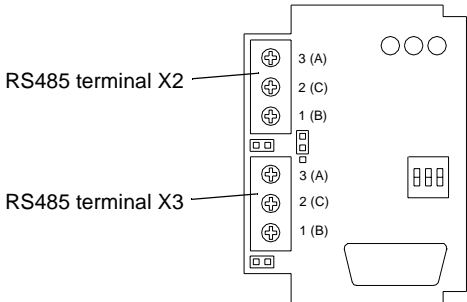


Figure 6 RS485 connection terminals X2 and X3.

Installation to RS232 Bus

- 1 Make sure power is not connected to the ACS140.
- 2 Connect the ACS100-PAN control panel into the drive.
- 3 Connect power to ACS140.
- 4 Set up communication: station number, communication speed of the ACS 140 and parity. See Chapter 3 – Programming.
- 5 Set up other drive parameters as needed. Refer to ACS140 Programming Guide and chapter 3 of this manual.
- 6 Disconnect power from the ACS140.
- 7 Set the operation mode of the adapter to RS232 with jumper S4.
- 8 Connect the adapter to the ACS 140. Connect the RS232 cable.

Skip steps 2-6 if the default parameter setting of the ACS 140 can be used.

Wiring

RS232 bus is a point-to-point type bus. Typical usage is to connect the drive into the serial port of a PC.

The maximum RS232 cable length is 3 metres. The RS232 cable is not included in the delivery.

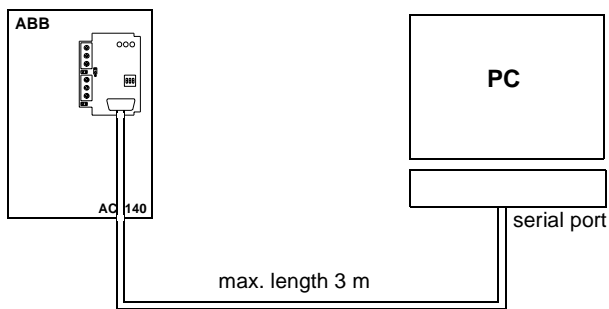
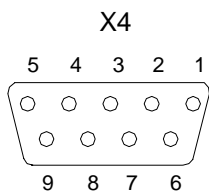


Figure 7 RS232 wiring.



X4		Description
1		NC
2		TxD
3		RxD
4	}	DTR
5		SGND
6		DSR
7	}	RTS
8		CTS
9		NC

Figure 8 RS232 signals. DTR and DSR as well as RTS and CTS signals are internally connected. The RS232 cable should not have TxD and RxD signals connected across.

Earthing and Termination

RS485 Bus

The RS485 network should not be directly earthed at any point. All the devices on the network should be well earthed using their corresponding earthing terminals.

As always, the earthing wires should not form any closed loops, and all the devices should be earthed to a common earth.

The RS485 network must be terminated using $120\ \Omega$ resistors at both ends of the network as shown in Figure 9. These resistors are already resident on the adapter. Use jumpers S2 and S3 to connect the termination resistors.



Figure 9 Termination for the RS485 link.



The connections may only be made with the drive disconnected from the power source.

Chapter 3 – Programming

This chapter describes how to program the ACS 140 drive for Modbus communication. The reader should be already familiar with programming the drive parameters using the ACS 100 - PAN control panel, and the way the parameters are arranged in groups. For details, see the *ACS 140 Programming Guide*.

General

When the ACS 100 - PAN control panel is attached to the drive, the panel communicates using the Modbus protocol and the settings given in Table 2.

When power is connected, the ACS 140 will automatically check for the presence of the panel. If the panel is detected, the ACS 140 will set up the Modbus communication using the default settings shown in Table 2. This communication setting is then used until the next power down.

If the panel (or any other master that uses communication setting shown in Table 2) is NOT detected in 4 seconds after power up, the ACS 140 will set up Modbus communication normally, using the parameters 5201 STATION ID, 5202 COMM SPEED and 5203 PARITY. This communication setting is then used until the next power-down.

Note! If any of the parameters 5201 STATION ID, 5202 COMM SPEED and 5203 PARITY has been altered, the control panel will operate only if it is connected before the power is applied to the ACS 140 (or immediately after power-up).

Note! If any of the parameters 5201 STATION ID, 5202 COMM SPEED and 5203 PARITY is altered, the modification takes effect only on the next power-up, and if the ACS 100 - PAN control panel is not connected when the power is applied.

Table 2 ACS 140 (ACS 400) default communication settings.

Station number	Communication speed	Parity bit	Stop bits
1	9600 bps	none	two

Communication Settings

The configuration information is in Group 52. The contents of this group are shown in Table 3 below.

Table 3 Communication parameters.

Code	Name	Range	Default	User
Group 52				
SERIAL COMM				
5201	STATION NUMBER	1 - 247	1	
5202	COMM SPEED	3 = 300 bps 6 = 600 bps 12 = 1200 bps 24 = 2400 bps 48 = 4800 bps 96 = 9600 bps 192 = 19200 bps	96 (9600 bps)	
5203	PARITY	0 - 2	0 (NONE)	
5204	COMM FAULT TIME	0.1 - 60.0 s	1.0 s	
5205	COMM FAULT FUNC	0 - 3	0 (NOT SEL)	

Code	Name
5201	<p>STATION NUMBER Sets the slave number for the ACS 140 in Modbus network.</p> <p>Range: 1 - 247</p> <p>Note! Modifications take effect only on the next power up.</p>
5202	<p>COMM SPEED Defines the communication speed of the ACS 140 in bits per second (bps).</p> <p>3 = 300 bps 48 = 4800 bps 6 = 600 bps 96 = 9600 bps 12 = 1200 bps 192 = 19200 bps 24 = 2400 bps</p> <p>Note! Modifications take effect only on the next power-up.</p>
5203	<p>PARITY Defines the parity to be used in Modbus communication. Parameter also defines the number of stop bits. In Modbus communication, the number of stop bits is 2 with no parity bit, and 1 with even or odd parity.</p> <p>0 = NONE 1 = EVEN 2 = ODD</p> <p>Note! Modifications take effect only on the next power-up.</p>
5204	<p>COMM FAULT TIME Time limit for communication loss detection. This parameter is used together with parameter 5205 COMM FAULT FUNC to define the ACS 140 operation when the communication with the master device in the Modbus network is lost.</p> <p>The master device in the Modbus network must signal its presence to every slave device (ACS 140) in the network by periodically writing Command Word, External Reference 1 or External Reference 2 to each ACS 140 in the network. Maximum write period is set by this parameter.</p> <p>Range: 0.1 - 60.0 s</p> <p>Note! During the first 4 seconds after power-up, communication fault is not evaluated to compensate for possible long system start-up delay.</p>
5205	<p>COMM FAULT FUNC Operation in case the communication with the master device is lost. The time limit for communication loss detection is set by parameter 5204 COMM FAULT TIME.</p> <p>0 = NOT SEL Communication loss is not detected.</p> <p>1 = FAULT A fault indication is shown on the control panel display and included in the Status Word. The ACS 140 coasts to stop.</p> <p>2 = CONST SPEED 7 A warning indication is shown on the control panel display and included in the Status Word. The speed reverts to the level set by parameter 1208 CONST SPEED 7.</p> <p>3 = REFERENCE A warning indication is shown on the control panel display and included in the Status Word. The speed reverts to the level set by the current frequency reference.</p> <p>Warning! If CONST SPEED 7 or REFERENCE is selected, ensure it is safe to continue operation in case communication with the master device fails.</p>

Control Locations

The ACS 140 drive can receive control information from multiple sources, including discrete I/O, analogue I/O, keypad, and serial communication channel.

To control the ACS 140 via the serial communication, it must be parameterised to accept control commands and/or frequency references from the serial communication channel. In addition, ACS 140 must be in remote control.

Table 4 Parameters for selecting control location.

Code	Name	Range	Default	User	S	M
Group 10						
COMMAND INPUTS						
1001	EXT1 COMMANDS	0-10	*		✓	✓
1002	EXT2 COMMANDS	0-10	*		✓	✓
Group 11						
REFERENCE SELECT						
1102	EXT1/EXT2 SEL	1-8	*		✓	✓
1103	EXT REF1 SELECT	0-8	*		✓	✓
1106	EXT REF2 SELECT	0-8	*		✓	✓
Group 16						
SYSTEM CONTROLS						
1601	RUN ENABLE	0-6	*		✓	✓
1604	FAULT RESET SEL	0-7	6 (START/STOP)		✓	

S = Parameters can be modified only when the drive is stopped.

M = Default value depends on the selected macro.

Code	Description
1001	<p>EXT1 COMMANDS</p> <p>Defines the connections and the source of Start/Stop/Direction commands for External control location 1 (EXT1).</p> <p>0 = NOT SEL No Start/Stop/Direction command source for EXT1 is selected.</p> <p>1 = DI1 Two-wire Start/Stop connected to digital input DI1. DI1 deactivated = Stop; DI1 activated = Start. *</p> <p>2 = DI1,2 Two-wire Start/Stop, Direction. Start/Stop is connected to digital input DI1 as above. Direction is connected to digital input DI2. DI2 deactivated = Forward; DI2 activated = Reverse. To control direction, value of parameter 1003 DIRECTION should be REQUEST.</p> <p>3 = DI1P,2P Three-wire Start/Stop. Start/Stop commands are given by means of momentary push-buttons (the P stands for "pulse"). The Start push-button is normally open, and connected to digital input DI1. The Stop push-button is normally closed, and connected to digital input DI2. Multiple Start push-buttons are connected in parallel; multiple Stop push-buttons are connected in series. *,**</p> <p>4 = DI1P,2P,3 Three-wire Start/Stop, Direction. Start/Stop connected as with DI1P,2P. Direction is connected to digital input DI3. DI3 deactivated = Forward; DI3 activated = Reverse. To control Direction, value of parameter 1003 DIRECTION should be REQUEST. **</p> <p>5 = DI1P,2P,3P Start Forward, Start Reverse, and Stop. Start and Direction commands are given simultaneously with two separate momentary push-buttons (the P stands for "pulse"). The Stop push-button is normally closed, and connected to digital input DI3. The Start Forward and Start Reverse push-buttons are normally open, and connected to digital inputs DI1 and DI2 respectively. Multiple Start push-buttons are connected in parallel, and multiple Stop push-buttons are connected in series. To control direction, value of parameter 1003 DIRECTION should be REQUEST. **</p> <p>6 = DI5 Two-wire Start/Stop, connected to digital input DI5. DI5 deactivated = Stop and DI5 activated = Start. *</p> <p>7 = DI5,4 Two-wire Start/Stop/Direction. Start/Stop is connected to digital input DI5. Direction is connected to digital input DI4. DI4 deactivated = Forward and DI4 activated = Reverse. To control direction, value of parameter 1003 DIRECTION should be REQUEST.</p> <p>8 = KEYPAD The Start/Stop and Direction commands are given from the control panel when External control location 1 is active. To control direction, value of parameter 1003 DIRECTION should be REQUEST.</p> <p>9 = DI1F,2R Start forward command is given when DI1= activated and DI2 = deactivated. Start reverse command is given if DI1 is deactivated and DI2 is activated. In other cases Stop command is given.</p> <p>10 = COMM The Start/Stop and Direction commands are given through serial communication.</p> <p>*Note! In cases 1,3,6 direction is set with parameter 1003 DIRECTION. Selecting value 3 (REQUEST) fixes direction to Forward.</p> <p>**Note! Stop signal must be activated before Start command can be given.</p>

The table continues on the next page.

Code	Description
1002	<p>EXT2 COMMANDS</p> <p>Defines the connections and the source of Start, Stop and Direction commands for external control location 2 (EXT2).</p> <p>Refer to parameter 1001 EXT1 COMMANDS above.</p>
1102	<p>EXT1/EXT2 SEL</p> <p>Sets the input used for selecting the external control location, or fixes it to EXT1 or EXT2. The external control location of both Start/Stop/Direction commands and reference is determined by this parameter.</p> <p>1...5 = DI1...DI5 External control location 1 or 2 is selected according to the state of the selected digital input (DI1 ... DI5), where deactivated = EXT1 and activated = EXT2.</p> <p>6 = EXT1 External control location 1 (EXT1) is selected. The control signal sources for EXT1 are defined with parameter 1001 (Start/Stop/Direction commands) and parameter 1103 (reference).</p> <p>7 = EXT2 External control location 2 (EXT2) is selected. The control signal sources for EXT2 are defined with parameter 1002 (Start/Stop/Direction commands) and parameter 1106 (reference).</p> <p>8 = COMM External control location 1 or 2 is chosen through serial communication.</p>

The table continues on the next page.

Code	Description
1103	<p>EXT REF1 SELECT This parameter selects the signal source of external reference 1.</p> <p>0 = KEYPAD Reference is given from the control panel.</p> <p>1 = AI 1 Reference is given through analogue input 1.</p> <p>2 = AI 2 Reference is given through analogue input 2.</p> <p>3 = AI1/JOYST; 4 = AI2/JOYST Reference is given through analogue input 1 (or 2 accordingly) configured for a joystick. The minimum input signal runs the drive at maximum reference in the reverse direction. The maximum input signal runs the drive at maximum reference in the forward direction (See Figure 10). See also parameter 1003 DIRECTION.</p> <p>Caution: Minimum reference for joystick should be 0.3 V (0.6 mA) or higher. If a 0 ... 10 V signal is used, the ACS 140 will operate at maximum reference in the reverse direction if the control signal is lost. Set parameter 1301 MINIMUM AI1 to a value 0.3 V or higher, and parameter 3001 AI<MIN FUNCTION to 1 (FAULT), and the ACS 140 will stop in case the control signal is lost.</p> <div data-bbox="186 695 823 1107" data-label="Figure"> </div> <p>Figure 10 Joystick control. Maximum for external reference 1 is set with Parameter 1105, minimum with Parameter 1104.</p> <p>5 = DI3U,4D(R) Speed reference is given through digital inputs as motor potentiometer control. Digital input DI3 increases the speed (the U stands for "up"), and digital input DI4 decreases the speed (the D stands for "down"). (R) indicates that the reference will be reset to zero when a Stop command is given. The rate of change of the reference signal is controlled by parameter 2204 ACCELER TIME 2.</p> <p>6 = DI3U,4D Same as above, except that the speed reference is not reset to zero on a Stop command. When the ACS 140 is started, the motor will ramp up at the selected acceleration rate to the stored reference.</p> <p>7 = DI4U,5D Same as above, except that the digital inputs in use are DI4 and DI5.</p> <p>8= COMM The reference is given through serial communication.</p>
1106	<p>EXT REF2 SELECT This parameter selects the signal source for external reference 2. The alternatives are the same as with external reference 1.</p>

Code	Description
1601	<p>RUN ENABLE Selects the source of the run enable signal.</p> <p>0 = NOT SEL The ACS 140 is ready to start without an external run enable signal.</p> <p>1...5 = DI1 ... DI5 To activate the run enable signal, the selected digital input must be activated. If the voltage drops and deactivates the selected digital input, the ACS 140 will coast to stop and not start until the run enable signal resumes.</p> <p>6 = COMM The run enable signal is given through serial communication (Command Word bit 3).</p>
1604	<p>FAULT RESET SEL Fault reset source.</p> <p>Note! Fault reset is always possible with control panel.</p> <p>0 = KEYPAD ONLY Fault reset is executed from the control panel keypad.</p> <p>1...5 = DI1 ... DI5 Fault reset is executed from a digital input. Reset is activated by deactivating the input.</p> <p>6 = START/STOP Fault reset is activated by Stop command.</p> <p>Note! This setting should not be used when start, stop and direction commands are given through serial communication.</p> <p>7 = COMM Fault reset is executed through serial communication (Command Word bit 7).</p>

Diagnostic Counters

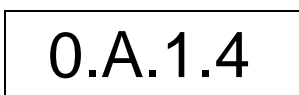
Diagnostic counters can be used for debugging the Modbus system.

Counters will roll over from 65535 to 0. The counter values are stored to permanent memory when power is disconnected.

Counters can be reset from the control panel by pressing the UP and DOWN buttons simultaneously when in parameter set mode, or by setting them to zero via the serial communication channel.

Code	Name	Range	User
Group 52			
SERIAL COMM			
5206	BAD MESSAGES	0 - 65535	
5207	GOOD MESSAGES	0 - 65535	
5208	BUFFER OVERRUNS	0 - 65535	
5209	FRAME ERRORS	0 - 65535	
5210	PARITY ERRORS	0 - 65535	
5211	CRC ERRORS	0 - 65535	
5212	BUSY ERRORS	0 - 65535	
5213	SER FAULT MEM 1	0 - 3	
5214	SER FAULT MEM 1	0 - 3	
5215	SER FAULT MEM 3	0 - 3	

Note! Parameters 5206 - 5212 are displayed in hexadecimal format by the control panel. The panel displays three decimal points to indicate a hexadecimal number.



0.A.1.4

Figure 11 An example of the ACS 100 - PAN displaying a hexadecimal number A14 (2580 decimal).

Code	Description
5206	BAD MESSAGES This diagnostics counter increases by one every time the ACS 140 finds any kind of communication error. During normal operation, this counter hardly ever increases.
5207	GOOD MESSAGES This diagnostics counter increases by one every time a valid Modbus message has been received by the ACS 140. During normal operation, this counter increases constantly.
5208	BUFFER OVERRUNS The longest possible message length for the ACS 140 is 32 bytes. If a message exceeding 32 bytes is received, this diagnostic counter increases by one every time a character is received and cannot be placed in the buffer.
5209	FRAME ERRORS This diagnostic counter increases by one every time when a character with a framing error is received from the bus. <ul style="list-style-type: none"> • Communication speed settings of the devices connected to the bus differ. • Ambient noise levels may be too high.
5210	PARITY ERRORS This diagnostic counter increases by one every time when a character with a parity error is received from the bus. <ul style="list-style-type: none"> • Parity settings of the devices connected in the bus differ. • Ambient noise levels may be too high.
5211	CRC ERRORS This diagnostic counter increases by one every time when a message with a CRC error is received. <ul style="list-style-type: none"> • Ambient noise levels may be too high. • CRC calculation is not performed correctly.
5212	BUSY ERRORS In Modbus network, only one device can transmit at any given time. This diagnostic counter increases by one every time the ACS 140 receives a character from the bus while it is still processing the previous message.
5213	SER FAULT MEM 1 Last Modbus exception code sent. Refer to "Exception Codes", starting page 23.
5214	SER FAULT MEM 2 Previous Modbus exception code sent.
5215	SER FAULT MEM 3 Oldest Modbus exception code sent.

Chapter 4 – Communication

This chapter describes the Modbus communication on ACS 140 drives.

Introduction to Modbus

Modbus is a serial, asynchronous protocol. The Modbus protocol does not specify the physical interface. Typical physical interfaces are RS232 and RS485, both of which are supported by the adapter.

Modbus is designed for integration with Modicon PLCs or other automation devices, and the services closely correspond to the PLC architecture. The ACS 140 drive 'looks like' a Modicon PLC on the network.

If detailed information regarding the Modicon Modbus protocol is required, contact your ABB supplier for a copy of Modbus Protocol Guide.

Register Read and Write

The ACS 140 has all drive parameter, control and status information mapped into a 4xxxx register area. This holding register area can be read from an external device, and an external device can modify the register values by writing to them.

There are no setup parameters for mapping the data to the 4xxxx register. The mapping is pre-defined and corresponds directly to the ACS 140 parameter grouping.

All parameters are available for both reading and writing. The parameter writes are verified for correct value, and for valid register addresses. Some parameters never allow writes (including Group 1 actual values), some parameters allow write only when the drive is stopped (including Group 99 setup variables), and some can be modified at any time (including e.g. Group 22 acceleration and deceleration ramp times).

Register Mapping

The drive parameters are mapped to the 4xxx area so that:

- 40001 – 40099 are reserved for drive control registers
- 40101 – 40199 is reserved for the actual values (parameter group 1)
- 40201 – 40299 is reserved for parameter group 2
- 40301 – 40399 is reserved for fault and alarm information
- ... other parameter groups
- 49901 – 49999 is reserved for the start-up data

In this mapping, the thousands and hundreds correspond to the group number, while the tens and ones correspond to the parameter number within a group.

Register addresses 4GGPP are shown in Table 5. In this table GG is the group number, and PP is the parameter number within the group

Table 5 Parameter mapping.

4GGPP	GG	PP
40001 – 40006	00 Drive control registers	01 Command word 02 Reference 1 03 Reference 2 04 Status word 05 Actual value 1 06 Actual value 2
40102 – 40130	01 OPERATING DATA	02 SPEED ... 30 OLDEST FAULT
41001 – 41003	10 COMMAND INPUTS	01 EXT1 COMMANDS 02 EXT2 COMMANDS 03 DIRECTION
41101 – 41108	11 REFERENCE SELECT	01 KEYPAD REF SEL ... 08 CONST SPEED 7
...
49901 – 49908	99 START-UP DATA	02 APPLIC MACRO ... 08 MOTOR NOM SPEED

The register addresses between the groups are invalid. No reads or writes are allowed for these addresses. If there is an attempt to read or write outside the parameter addresses, the Modbus interface will return an exception code to the controller.

Exception Codes

The ACS 140 supports the standard Modbus exception codes. These are shown in Table 6.

Table 6 Exception codes.

Code	Name	Meaning
01	ILLEGAL FUNCTION	The function code received in the query is not an allowable action for the slave. ACS 140 : Unsupported Command.
02	ILLEGAL DATA ADDRESS	The data address received in the query is not an allowable address for the slave. ACS 140 : Address outside groups
03	ILLEGAL DATA VALUE	A value contained in the query data field is not an allowable value for the slave. ACS 140 : Value outside min-max limits ACS 140 : Parameter is read-only ACS 140 : Message is too long ACS 140 : Parameter write not allowed when start is active ACS 140 : Parameter write not allowed when factory macro is selected

Function Codes

The ACS 140 supports the Modbus function codes given in Table 7. If any other function codes are used ACS 140 returns an exception response with error code 01 (illegal function).

Table 7 Function codes.

Code	Description
03	Read holding registers
06	Preset single register
16 (10 Hex)	Preset multiple registers

The Command Word

Holding register: 40001

The Command Word is the principal means for controlling ACS 140 from a fieldbus system. It is sent by the fieldbus master station to the drive. ACS 140 switches between its states according to the bit-coded instructions on the Command Word.

Note! In order to use Command Word the drive must be configured to receive control commands from the serial communication channel. Refer to “Control Locations” on page 14.

The contents of the Command Word is presented in the following table. The text in *italics* refers to the states in Figure 12.

Table 8 The Command Word.

Bit	Value	Description
0	1	Enter <i>READY TO OPERATE</i>
	0	Emergency OFF. Ramp to stop according to parameter 2203 DECELER TIME 1. Enter <i>OFF1 ACTIVE</i> ; proceed to <i>READY TO SWITCH ON</i> unless other interlocks (OFF2, OFF3) are active.
1	1	Continue operation (OFF2 inactive)
	0	Emergency OFF, coast to stop. Enter <i>OFF2 ACTIVE</i> ; proceed to <i>SWITCH-ON INHIBITED</i> .
2	1	Continue operation (OFF3 inactive)
	0	Emergency stop. Drive ramps to stop according to parameter 2205 DECELER TIME 2. Enter <i>OFF3 ACTIVE</i> ; proceed to <i>SWITCH-ON INHIBITED</i> .
3	0-1	Enter <i>OPERATION ENABLED</i> (Note that also the Run enable signal must be present on a digital input – see parameter 1601 RUN ENABLE.)
	0	Inhibit operation. Enter <i>OPERATION INHIBITED</i>
4		Unused.
5	1	Normal operation. Enter <i>RAMP FUNCTION GENERATOR: ACCELERATOR ENABLED</i>
	0	Halt ramping (Ramp Function Generator output held)
6	1	Normal operation. Enter <i>OPERATING</i>
	0	Force Ramp Function Generator input to zero.
7	0 - 1	Fault reset (enter <i>SWITCH-ON INHIBITED</i>)
	0	(Continue normal operation)
8 to 10		Unused
11	1	Select external control location 2 (EXT2)
	0	Select external control location 1 (EXT1)
12 to 15		Unused

References

References are 16-bit words containing a sign bit and a 15-bit integer. A negative reference (indicating reversed direction of rotation) is formed by calculating the two's complement from the corresponding positive reference.

Reference 1

Holding Register: 40002

Reference 1 can be used as the frequency reference REF1 for the ACS 140. Scaling: $20000 \hat{=} \text{EXT REF1 MAX}$ (Hz, parameter 1105). Scaling Parameter 1104 EXT REF1 MIN is not used.

The signal source of external reference 1 (REF1) must be set to COMM and external control location 1 (EXT1) must be activated. Refer to parameters 1103 EXT REF 1 SELECT and 1102 EXT1/EXT2 SEL.

Reference 2

Holding Register: 40003

Reference 2 can be used as the frequency reference REF2 for the ACS 140. Scaling: $10000 \hat{=} \text{EXT REF2 MAX}$ (% , parameter 1108). Scaling Parameter 1107 EXT REF2 MIN is not used.

The signal source of external reference 2 REF2 must be set to COMM and External control location 2 (EXT2) must be activated. Refer to parameters 1106 EXT REF 2 SELECT and 1102 EXT1/EXT2 SEL.

The Status Word

Holding Register: 40004

The Status Word is a read-only word containing information of the ACS 140 status.

The contents of Status Word is presented in the following table. The text in italics refers to the states in Figure 12.

Table 9 The Status Word.

Bit	Value	Description
0	1	<i>READY TO SWITCH ON</i>
	0	<i>NOT READY TO SWITCH ON</i>
1	1	<i>READY TO OPERATE</i>
	0	<i>OFF1 ACTIVE</i>
2	1	<i>OPERATION ENABLED</i>
	0	Not ready (<i>OPERATION INHIBITED</i>)
3	0 - 1	<i>FAULT</i>
	0	No fault
4	1	OFF2 inactive
	0	<i>OFF2 ACTIVE</i>
5	1	<i>OFF3</i> inactive
	0	<i>OFF3 ACTIVE</i>
6	1	<i>SWITCH-ON INHIBITED</i>
	0	
7	1	Alarm 10 - 21 is active
	0	No alarm
8	1	<i>OPERATING</i> . Actual value equals reference value (= is within tolerance limits).
	0	Actual value differs from reference value (= is outside tolerance limits)
9	1	Drive control location: REMOTE
	0	Drive control location: LOCAL
10	1	The value of first supervised parameter equals to or is greater than supervision limit. Refer to Group 32 Supervision.
	0	The value of first supervised parameter is below supervision limit
11	1	External control location 2 (EXT2) selected
	0	External control location 1 (EXT1) selected
12	1	Run Enable signal received
	0	No Run Enable signal received
13 to 15		Unused

Actual Values

Actual values are read-only values containing information on the operation of the drive. Actual values are 16-bit words containing sign bit and a 15-bit integer. A negative value is given as two's complement of the corresponding positive value.

Actual Value 1

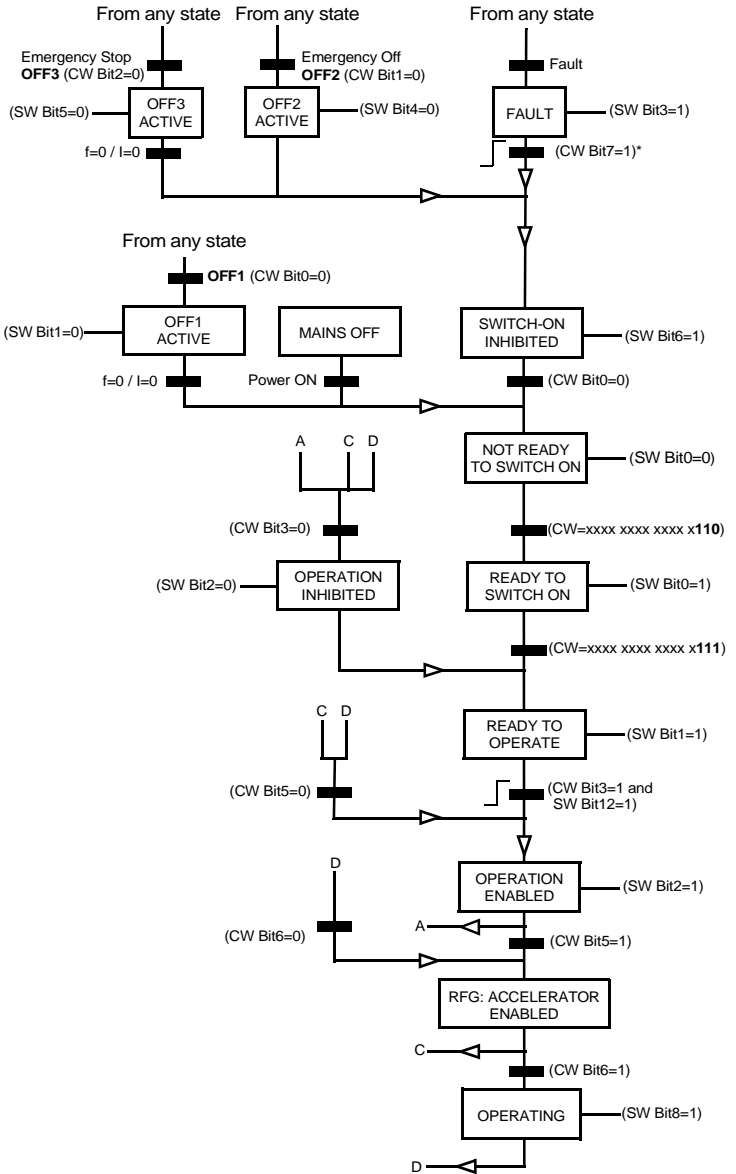
Holding Register: 40005

Actual output frequency. Scaling: $5000 \hat{=} 50$ Hz.

Actual Value 2

Holding Register: 40006

Actual output current. Scaling: $10 \hat{=} 1$ A.



*This state transition occurs also if the fault is reset from any other source (e.g. digital input).



- | | |
|---|-------------------------------|
|  State | I = Output current |
|  CW = Control Word | f = Output frequency |
| SW = Status Word | RFG = Ramp Function Generator |

Figure 12 The state machine for evaluation of start and stop signals.

Fault and Alarm Status

The ACS140 provides fault and alarm status words that are accessible only from the serial communication link (not from the control panel).

These status words are located in place of parameter group 3 (Modbus holding registers 40301- 40309). These registers also contain copies of the Command Word (40001) and Status Word (40004).

Registers 40301-40309 are generally read-only type; however, alarm words can be reset by writing zeros into the register. Table 10 lists the fault and alarm words.

Table 10 Fault and alarm status words.

No	Name	Description
40301	MAIN COMMAND WORD	Read-only copy of the Command Word (40001). See page 24.
40302	MAIN STATUS WORD	Read-only copy of the Status Word (40004). See page 26.
40305	FAULT WORD 1	Fault information. When a fault is active corresponding bit is set. Bit descriptions are given in Table 11.
40306	FAULT WORD 2	Fault information. Bits 0 - 7 of this register may be set if there is a hardware error in ACS 140 (fault codes 18 - 22).
40308	ALARM WORD 1	Alarm information. When an alarm is active corresponding bit is set. Bits remain set until whole alarm word is reset by writing 0 to it. See Table 12.

Table 11 *FAULT WORD 1 bit descriptions.*

Bit #	Description
0	Overcurrent
1	DC overvoltage
2	ACS140 overtemperature
3	Fault current
4	Output overload
5	DC undervoltage
6	Analogue input 1 fault
7	Analogue input 2 fault
8	Motor overtemperature
9	Panel loss
10	Parameters inconsistent
11	DC bus ripple too large
12	Motor stall
13	Serial communication loss
14	External fault
15	Output earth fault

Table 12 *ALARM WORD 1 bit descriptions.*

Bit #	Description
0	Overcurrent controller alarm
1	Overvoltage controller alarm
2	Undervoltage controller alarm
3	Direction lock alarm
4	Serial communication loss
5	Modbus exception generated locally
6	Analogue input 1 loss
7	Analogue input 2 loss
8	Panel loss
9	ACS 140 overtemperature
10	Motor overtemperature
11	Motor stall alarm

Chapter 5 – Fault Tracing

This chapter gives step-by-step diagnostics information for finding out the causes and corrections to the most common problems with the adapter.

Power LED of the adapter is illuminated, but Receive (RxD) and Transmit (TxD) LEDs are not blinking

- The master device is not transmitting.
- The cable is not correctly connected to connector X2/X3 (in RS485 mode) or X4 (in RS232 mode).
- Operation mode (RS485 or RS232) of the adapter is not correct: Check jumper S4.

Receive LED blinks but there is no response from the ACS 140 (Transmit LED is not blinking)

- The master device is not using the same communication settings as the ACS 140.
- The ACS 140 is using the communication settings of the control panel: Turn power off and then on again.

Receive and Transmit LEDs are blinking, but the drive does not follow commands given by the master device

- The drive is not in remote control mode.
- The drive parametering is incorrect: Control commands are not accepted from the serial communication channel.

Receive and Transmit LEDs are blinking, but the responses ACS 140 sends are not intelligible

- DIP switch S1 and parameter 5202 COMM SPEED do not have the same speed setting.
- Ambient noise level is too high.

The ACS 100-PAN control panel is not operating and panel display blinks

- Panel is not properly connected to the drive.
- The drive is using different communication settings from the panel: Connect the panel and then turn power off and then on again.

Group 52 is not visible on the control panel

- Make full parameter set visible by selecting menu function -LG- and pressing and holding ENTER button down until display blinks.

Take advantage of the group 52 diagnostic counters. If necessary, use parameter 9902 APPLIC MACRO to restore the parameter settings of the ACS 140 to their default values and then reconfigure the drive.

Appendix – Parameter Scaling

This Appendix shows all the ACS 140 parameters with their scalings and alternative settings.

This chapter is intended for people who are using the drive data through the Modbus connection, and need to know in what units the data is available for reading and writing.

The information is subject to change.

Effect of Resolution

Parameter values are read and written through serial communication using integer values. When the given parameter resolution is 0.1, desired value must be multiplied by 10 to produce the integer value.

For example, to set parameter 2202 ACCELER TIME 1 (resolution 0.1 s) to the value of 60.5 s, value 605 must be written through serial communication.

Signed Values

Normally, parameter values are represented as signed integers. Negative values are given in the 2's complement format. To calculate the 2's complement, take the corresponding positive value, negate it and add 1. Signed integer values range from -32768 to 32767.

Note! Diagnostic counter values (parameters 5206 - 5215) are represented as unsigned integers. In this case values extend from 0 to 65535.

The parameter list starts on the next page.

S = Parameters can be modified only when the drive is stopped.
M = Default value depends on the selected macro.

Table 13 Parameter settings and actual signals.

Code	Name	Range	Resolution	S	M
Group 99					
START-UP DATA					
9902	APPLIC MACRO	0 = FACTORY (0) 1 = ABB STANDARD 2 = 3-WIRE 3 = ALTERNATE 4 = MOTOR POTENTIOMETER 5 = HAND - AUTO 6 = PID CONTROL 7 = PREMAGNETISE	1	✓	
9905	MOTOR NOM VOLT	200, 208, 220, 230, 240, 380, 400, 415, 440, 460, 480 V	-	✓	✓
9906	MOTOR NOM CURR	$0.5 \cdot I_N - 1.5 \cdot I_N$	0.1 A	✓	
9907	MOTOR NOM FREQ	0-250 Hz	1 Hz	✓	✓
9908	MOTOR NOM SPEED	0-3600 rpm	1 rpm	✓	✓
Group 01					
OPERATING DATA					
0102	SPEED	0-9999 rpm	1 rpm		
0103	OUTPUT FREQ	0-250 Hz	0.1 Hz		
0104	CURRENT	-	0.1 A		
0106	POWER	-	0.1 kW		
0107	DC BUS VOLTAGE	0-999.9 V	0.1 V		
0109	OUTPUT VOLTAGE	0-480 V	0.1 V		
0110	ACS 140 TEMP	0-150 °C	0.1 °C		
0111	EXT REF 1	0-250 Hz	0.1 Hz		
0112	EXT REF 2	0-100 %	0.1 %		
0113	CTRL LOCATION	0 = LOCAL 1 = EXT1 2 = EXT2	1		
0114	RUN TIME	0-9999 h	1 h		
0115	kWh COUNTER	0-9999 kWh	1 kWh		
0116	APPL BLK OUTPUT	0-100 %	0.1 %		
0117	DI1-DI4 STATUS	Bit 0 : DI1 status Bit 1 : DI2 status Bit 2 : DI3 status Bit 3 : DI4 status			
0118	AI1	0-100 %	0.1 %		
0119	AI2	0-100 %	0.1 %		
0121	DI5 & RELAYS	Bit 0 : Relay 1 status Bit 1 : Relay 2 status Bit 2 : DI5 status			
0122	AO	0-20 mA	0.1 mA		
0124	ACTUAL VALUE 1	0-100 %	0.1 %		
0125	ACTUAL VALUE 2	0-100 %	0.1 %		
0126	CONTROL DEV	-100-100 %	0.1 %		
0128	LAST FAULT	0-22	1	-	
0129	PREVIOUS FAULT	0-22	1	-	

Code	Name	Range	Resolution	S	M
0130	OLDEST FAULT	0-22	1	-	
Group 10 COMMAND INPUTS					
1001	EXT1 COMMANDS	0 = NOT SEL 1 = DI1 2 = DI1,2 3 = DI1P,2P 4 = DI1P,2P,3 5 = DI1P,2P,3P 6 = DI5 7 = DI5,4 8 = KEYPAD 9 = DI1F,2R 10 = COMM	1	✓	✓
1002	EXT2 COMMANDS	0-10, see 1001 EXT1 COMMANDS	1	✓	✓
1003	DIRECTION	1 = FORWARD 2 = REVERSE 3 = REQUEST	1	✓	✓
Group 11 REFERENCE SELECT					
1101	KEYPAD REF SEL	1 = REF1 (Hz) 2 = REF2 (%)	1		✓
1102	EXT1/EXT2 SEL	1...5 = DI1...DI5 6 = EXT1 7 = EXT2 8 = COMM	1	✓	✓
1103	EXT REF1 SELECT	0 = KEYPAD 1 = AI 1 2 = AI 2 3 = AI 1/JOYST 4 = AI 2/JOYST 5 = DI3U,4D(R) 6 = DI3U,4D 7 = DI4U,5D	1	✓	✓
1104	EXT REF1 MIN	0-250 Hz	1 Hz		
1105	EXT REF1 MAX	0-250 Hz	1 Hz		✓
1106	EXT REF2 SELECT	0-8, see 1103 EXT REF1 SELECT	1	✓	✓
1107	EXT REF2 MIN	0-100 %	1 %		
1108	EXT REF2 MAX	0-500 %	1 %		
Group 12 CONSTANT SPEEDS					
1201	CONST SPEED SEL	0 = NOT SEL 1...5 = DI1...DI5 6 = DI1,2 7 = DI3,4 8 = DI4,5 9 = DI1,2,3 10 = DI3,4,5	1	✓	✓
1202	CONST SPEED 1	0-250 Hz	0.1 Hz		
1203	CONST SPEED 2	0-250 Hz	0.1 Hz		
1204	CONST SPEED 3	0-250 Hz	0.1 Hz		
1205	CONST SPEED 4	0-250 Hz	0.1 Hz		
1206	CONST SPEED 5	0-250 Hz	0.1 Hz		
1207	CONST SPEED 6	0-250 Hz	0.1 Hz		
1208	CONST SPEED 7	0-250 Hz	0.1 Hz		

Code	Name	Range	Resolution	S	M
Group 13					
ANALOGUE INPUTS					
1301	MINIMUM AI1	0-100 %	1 %		
1302	MAXIMUM AI1	0-100 %	1 %		
1303	FILTER AI1	0-10 s	0.1 s		
1304	MINIMUM AI2	0-100 %	1 %		
1305	MAXIMUM AI2	0-100 %	1 %		
1306	FILTER AI2	0-10 s	0.1 s		
Group 14					
RELAY OUTPUTS					
1401	RELAY OUTPUT 1	0 = NOT SEL 1 = READY 2 = RUN 3 = FAULT (-1) 4 = FAULT 5 = ALARM 6 = REVERSED 7 = SUPRV1 OVER 8 = SUPRV1 UNDER 9 = SUPRV2 OVER 10 = SUPRV2 UNDER 11 = AT SET POINT	1		
1402	RELAY OUTPUT 2	0-11, see 1401 RELAY OUTPUT 1	1		
Group 15					
ANALOGUE OUTPUT					
1501	AO CONTENT	102-130	1		
1502	AO CONTENT MIN	x-y	z		
1503	AO CONTENT MAX	x-y	z		✓
1504	MINIMUM AO	0.0-20.0 mA	0.1 mA		
1505	MAXIMUM AO	0.0-20.0 mA	0.1 mA		
1506	FILTER AO	0-10 s	0.1 s		
Group 16					
SYSTEM CONTROLS					
1601	RUN ENABLE	0 = NOT SEL 1...5 = DI1...DI5 6 = COMM	1	✓	✓
1602	PARAMETER LOCK	0 = LOCKED 1 = OPEN 2 = NOT SAVED	1		
1604	FAULT RESET SEL	0 = KEYPAD ONLY 1...5 = DI1...DI5 6 = START/STOP 7 = COMM	1	✓	
Group 20					
LIMITS					
2003	MAX CURRENT	$0.5 \cdot I_N - 1.5 \cdot I_N$	0.1 A		
2005	OVERVOLT CTRL	0 = DISABLE 1 = ENABLE	1		
2006	UNDERVOLT CTRL	0 = DISABLE 1 = ENABLE (TIME) 2 = ENABLE	1		
2007	MINIMUM FREQ	0-250 Hz	1 Hz		
2008	MAXIMUM FREQ	0-250 Hz	1 Hz	✓	✓

Code	Name	Range	Resolution	S	M
Group 21 START/STOP					
2101	START FUNCTION	1 = RAMP 2 = FLYING START 3 = TORQUE BOOST 4 = FLY + BOOST	1		
2102	STOP FUNCTION	1 = COAST 2 = RAMP	1		
2103	TORQ BOOST CURR	$0.5 \cdot I_N - 2.0 \cdot I_N$	0.1 A		
2104	STOP DC INJ TIME	0-250 s	0.1 s		
2105	PREMAGN SEL	0 = NOT SEL 1...5 = DI1...DI5 6 = CONST	1	✓	✓
2106	PREMAGN MAX TIME	0-250 s	1 s		
Group 22 ACCEL/DECEL					
2201	ACC/DEC 1/2 SEL	0 = NOT SEL 1...5 = DI1...DI5	1	✓	✓
2202	ACCELER TIME 1	0.1-1800 s	0.1 s		
2203	DECELER TIME 1	0.1-1800 s	0.1 s		
2204	ACCELER TIME 2	0.1-1800 s	0.1 s		
2205	DECELER TIME 2	0.1-1800 s	0.1s		
2206	RAMP SHAPE	0 = LINEAR 1 = FAST S CURVE 2 = MEDIUM CURVE 3 = SLOW S CURVE	1		
Group 25 CRITICAL FREQ					
2501	CRIT FREQ SEL	0 = OFF 1 = ON	1		
2502	CRIT FREQ 1 LO	0-250 Hz	1 Hz		
2503	CRIT FREQ 1 HI	0-250 Hz	1 Hz		
2504	CRIT FREQ 2 LO	0-250 Hz	1 Hz		
2505	CRIT FREQ 2 HI	0-250 Hz	1 Hz		
Group 26 MOTOR CONTROL					
2603	IR COMPENSATION	0-30 V	1	✓	
2604	IR COMP RANGE	0-250 Hz	1 Hz	✓	
2605	LOW NOISE	0 = STANDARD 1 = LOW NOISE	1	✓	
2606	U/f RATIO	1 = LINEAR 2 = SQUARE	1	✓	
Group 30 FAULT FUNCTIONS					
3001	AI<MIN FUNCTION	0 = NOT SEL 1 = FAULT 2 = CONST SPEED7 3 = LAST SPEED	1		
3002	PANEL LOSS	1 = FAULT 2 = CONST SPEED7 3 = LAST SPEED	1		
3003	EXTERNAL FAULT	0 = NOT SEL 1...5 = DI1...DI5	1		

Code	Name	Range	Resolution	S	M
3004	MOT THERM PROT	0 = NOT SEL 1 = FAULT 2 = WARNING	1		
3005	MOT THERM TIME	256-9999 s	1 s		
3006	MOT LOAD CURVE	50-150 %	1 %		
3007	ZERO SPEED LOAD	25-150 %	1 %		
3008	BREAK POINT	1-250 Hz	1 Hz		
3009	STALL FUNCTION	0 = NOT SEL 1 = FAULT 2 = WARNING	1		
3010	STALL CURRENT	$0.5 \cdot I_N - 1.5 \cdot I_N$	0.1 A		
3011	STALL FREQ HI	0.5-50 Hz	0.1 Hz		
3012	STALL TIME	10...400 s	1 s		
Group 31					
AUTOMATIC RESET					
3101	NR OF TRIALS	0-5	1		
3102	TRIAL TIME	1.0-180.0 s	0.1 s		
3103	DELAY TIME	0.0-3.0 s	0.1 s		
3104	AR OVERCURRENT	0 = DISABLE 1 = ENABLE	1		
3105	AR OVERVOLTAGE	0 = DISABLE 1 = ENABLE	1		
3106	AR UNDERVOLTAGE	0 = DISABLE 1 = ENABLE	1		
3107	AR AI<MIN	0 = DISABLE 1 = ENABLE	1		
Group 32					
SUPERVISION					
3201	SUPERV 1 PARAM	102 -130	1		
3202	SUPERV 1 LIM LO	x-y	z		
3203	SUPERV 1 LIM HI	x-y	z		
3204	SUPERV 2 PARAM	102 - 130	1		
3205	SUPERV 2 LIM LO	x-y	z		
3206	SUPERV 2 LIM HI	x-y	z		
Group 33					
INFORMATION					
3301	SW VERSION	0.0.0.0-f.f.f	-		
3302	TEST DATE	yy.ww	-		
Group 40					
PID-CONTROL					
4001	PID GAIN	0.1-100	0.1		
4002	PID INTEG TIME	0.1-320 s	0.1 s		
4003	PID DERIV TIME	0-10 s	0.1 s		
4004	PID DERIV FILTER	0-10 s	0.1 s		
4005	ERROR VALUE INV	0 = NO 1 = YES	1		

Code	Name	Range	Resolution	S	M
4006	ACTUAL VAL SEL	1 = ACT1 2 = ACT1-ACT2 3 = ACT1+ACT2 4 = ACT1*ACT2 5 = ACT1/ACT2 6 = MIN(A1,A2) 7 = MAX(A1,A2) 8 = sq(A1-A2) 9 = sqA1+sqA2	1	✓	
4007	ACT1 INPUT SEL	1 = A1 2 = A2	1	✓	
4008	ACT2 INPUT SEL	1 = A1 2 = A2	1	✓	
4009	ACT1 MINIMUM	-1000-1000 %	1 %		
4010	ACT1 MAXIMUM	-1000-1000 %	1 %		
4011	ACT2 MINIMUM	-1000-1000 %	1 %		
4012	ACT2 MAXIMUM	-1000-1000 %	1 %		
4013	PID SLEEP DELAY	0.0-3600 s	0.1 s		
4014	PID SLEEP LEVEL	0.0-120 Hz	0.1 Hz		
4015	WAKE-UP LEVEL	0.0-100 %	0.1 %		
Group 52					
SERIAL COMM					
5201	STATION NUMBER	1 - 247	1		
5202	COMM SPEED	3 = 300 bps 6 = 600 bps 12 = 1200 bps 24 = 2400 bps 48 = 4800 bps 96 = 9600 bps 192 = 19200 bps	96		
5203	PARITY	0 = NONE 1 = EVEN 2 = ODD	1		
5204	CONN FAULT TIME	0.1 - 60.0 s	0.1 s		
5205	COMM FAULT FUNC	0 = NOT SEL 1 = FAULT 2 = CONST SPEED 7 3 = REFERENCE	1		
5206	BAD MESSAGES	0 - 65535	1		
5207	GOOD MESSAGES	0 - 65535	1		
5208	BUFFER OVERRUNS	0 - 65535	1		
5209	FRAME ERRORS	0 - 65535	1		
5210	PARITY ERRORS	0 - 65535	1		
5211	CRC ERRORS	0 - 65535	1		
5212	BUSY ERRORS	0 - 65535	1		
5213	SER FAULT MEM 1	0 - 3	1		
5214	SER FAULT MEM 2	0 - 3	1		
5215	SER FAULT MEM 3	0 - 3	1		



3AFY 61492828 R0125 REV A

EN

Effective: 1.10.1998

© 1998 ABB Industry Oy

Subject to change without prior notice.

ABB Industry Oy
P.O. Box 184
00381 Helsinki
FINLAND

Telephone +358-10-222 000

Telefax +358-10-22 22681

